



Sixty Auto

LEGACY,
ICONIC DESIGN
& PRECISION



Nestled quietly within the heart of Monaco is our small, but perfectly formed factory, hand-crafting espresso machines since 1956. We combine a genuine passion for innovation and coffee excellence, with exceptional quality and reliability to produce the finest machines for any circumstance or environment.

www.conti-espresso.com

ESTD 1956

Conti
MONACO



Sixty Auto



The Sixty Auto is an evolution of Conti limited model created for its 60th anniversary. Designed for coffee lovers, the Sixty combines high performance and elegance. This machine is 100% hand-crafted in Monaco.



Multi boiler heating system

Each coffee boiler and coffee group are accurately temperature controlled by their own PID system and supplied with preheated water from our unique heat exchange system. The Sixty Auto ensures a high temperature accuracy by offering the nearest half-degree coffee boiler setting.



Soft pre-infusion

Intended to replicate the simplistic but ultimately effective one-way pre-infusion found on the former lever style espresso machine, our in-house system ensures that the barista can fully saturate the coffee puck under controlled low pressure. This results in incredibly consistent extraction, reduction in channeling and espresso with increased body and better mouthfeel. The Sixty Auto goes even further with a pre-infusion program until 20s.



Design & lower environment impact

An iconic design with beautiful lines and high-end materials. The wood offers a natural and premium touch, combining with sustainable and recyclable metals. In addition, the steam boiler and its performance has been adjusted to reduce the energy consumption.

Additional Features:

'Infinite Actuate' steam Lever
Allowing the barista precise control over steam flow, making perfect texturing simple, even with an array of sensitive alternative milks.

Efficient and accurate electronics

The shot timer's display shows the barista what he needs to do to pour a perfect shot: time of extraction combined with temperatures setting.

Customization services

In addition to our standard range, Conti also offers you the possibility to customize your espresso machine so as to enhance your brand identity or create your unique espresso experience.

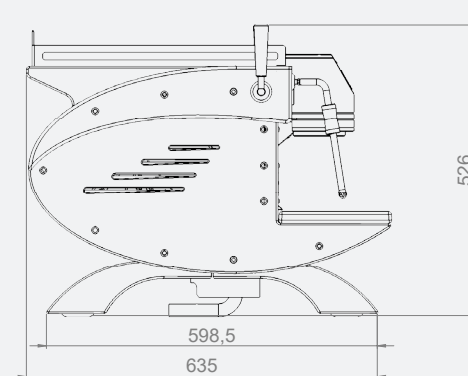
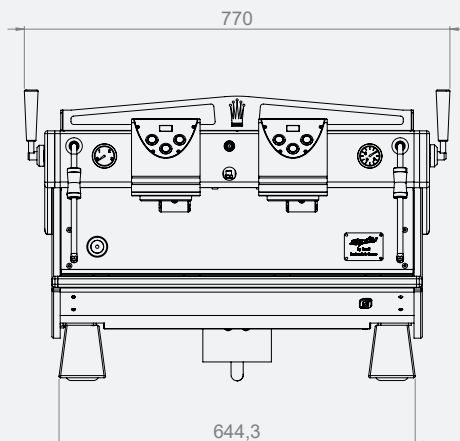

2 Groups

Height (mm)	526
Width (mm)	770
Depth (mm)	635
Weight (kg)	85
Steam Boiler Size (Litres)	7
Coffee Boiler Size (Litres)	0.9 x 2
Group Element (W)	100
Steam Boiler Element (W)	2400
Coffee Boiler Element (W)	1000 x 2
Total Power (W)	4900
Voltage (V)	400



Conti Monaco
Email: conti@conti-espresso.com
Tel: +377 93 10 43 43
www.conti-espresso.com

1 avenue Albert II
B.P 119
MC 98007
Monaco Cedex

