

Opera 2.0



Opera. The full story
Watch the video



Versions

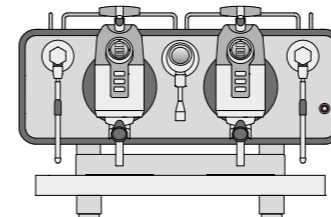

31" / 786 mm

2 group OP

- 2 steam taps
- 1 water tap
- 1 one-cup filter holder
- 2 two-cup filter holders

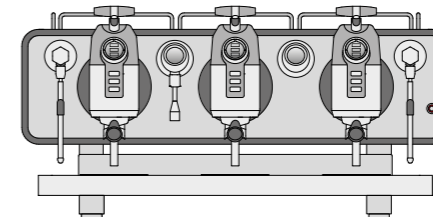

41" / 1040 mm

3 group OP

- 2 steam taps
- 1 water tap
- 1 one-cup filter holder
- 3 two-cup filter holders

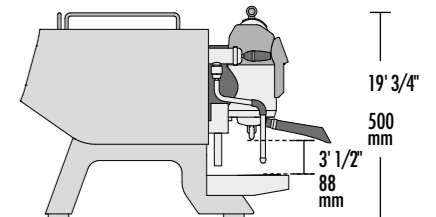

19' 3/4" / 507 mm
25' 2/3" / 653 mm

TALL VERSION

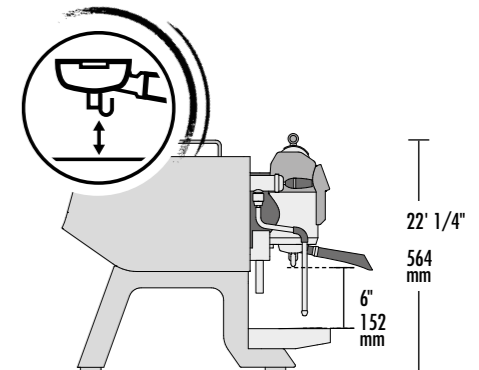

22' 1/4"
564 mm

MULTI-BOILER SYSTEM

High accuracy thermal stability thanks to the Sanremo multiboiler system with sophisticated electronic boards that continuously control temperature throughout all phases of extraction. Steam and coffee circuits work totally independent to maximize performance in every working condition (also under high workload).

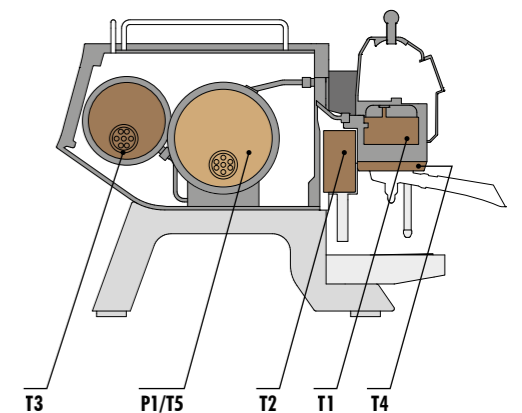

Technical data

		2 group	3 group
voltage	V	220-240 1N / 380-415 3N	
max input boiler/steam boiler's resistor power	kW	7.7 / 3.5	8.3 / 3.5
		8.5 / 4.5	9.1 / 4.5
steam boiler services	lt	8	10
external pump power	kW	0.15	0.15
preheating boiler capacity	lt	2.8	2.8
preheating boiler resistance power	kW	1.5	1.5
cup-heater power	kW	0.20	0.25
units boiler capacity	lt	1.0	1.5
units boiler resistance power	kW	1.6	2.4
net weight	lb / kg	200 / 91	249 / 113
gross weight (with shipping crate)	lb / kg	308 / 140	375 / 170.5



The Revolution

Be in control, express yourself

8

9

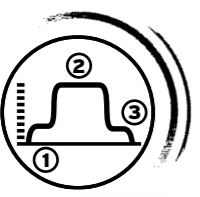

DOUBLE SELECTION BUTTONS
Easy-touch setting with 6 different profiles for individual groups

SMART LEVER
Coffee doses fast manual selection

CDS SYSTEM
Maximum precision and full control on the three phases of coffee extraction



POWER DRY STEAM
Low additional liquid during the milk steaming

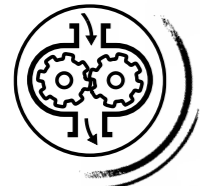

GEAR PUMP PERFORMANCE
High and constant pressure in all conditions



EVERYTHING UNDER CONTROL
System digital display to provide visibility of all working parameters

HEART OF STEEL

- For maximum thermal stability:
- Groups in AISI 316L weight 22 lb / 10 kg each
 - Filter holders AISI 316
 - Boilers AISI 316

WI-FI CONNECTION



EASY APP
Tablet or smartphone barista's Webapp for setting parameters



Opera. The Revolution
Link to the website

Characteristics

AISI 316L STEEL GROUPS WITH 22 lb / 10 kg PURE STEEL
Exclusive Sanremo design ensure exceptional thermal stability and maximum resistance to oxidation and lime scale.

AISI 316 STAINLESS STEEL FILTER HOLDER WITH "COMPETITION FILTER"
Exclusive Sanremo design, with shape and volume designed to capture the best coffee aromas and fragrances.

AISI 316L STAINLESS STEEL FREE MOTION STEAM TAPS
Flexible control system for producing and dispensing steam.

AISI 316L STAINLESS STEEL STEAM WAND "COOL TOUCH"
Anti-burning feature even in conditions of prolonged use, fitted with "Latte Art" high-performance steam terminals.

CONTROL COFFEE DELIVERY SYSTEM (CDS)
Three phases extraction parameters full control (pre-infusion, infusion, post-infusion).

INDEPENDENT ADJUSTMENT OF THE PID INFUSION WATER TEMPERATURE
Precision setting (gradient $\pm 0.1^\circ\text{C}$ with measured constancy lower than 0.2°C).

INFUSION WATER DISPLAY
Indicates tea and herbal teas water brewing temperature. (In the two group it is shown with the steam boiler display)

STEAM BOILER DISPLAY
Indicates steam boiler temperature and pressure. (In the two group Opera it is shown with the infusion water display)

COFFEE UNIT SINGLE DISPLAY
Controls of all coffee extraction parameters.

MACHINE'S PROGRAMMING PARAMETERS DISPLAY
The internal display is a handy programming interface for the maintenance technician.

MIXED INFUSION HOT WATER FOR TEA AND HERBAL TEAS
Instantaneous mixing of fresh water and steam for a better chemical and organoleptic quality.

GEAR PUMPS
Dedicated to each individual group, allow to change the pressure during infusion.

STEAM CONTROL ADJUSTABLE ELECTRONIC PRESSURE SWITCH
Sensor with 0.02 bar precision that allows the chosen pressure and steam in the boiler to be kept constant in all conditions of use.

PROGRAMMABLE CUP WARMER TEMPERATURE
Allows the cups to be kept at the optimum temperature in the most different climatic conditions.

EASY SERVICE
Fast access to the internal parts for quick and easy technical service.

AUTO-DIAGNOSIS, STATISTICAL DATA, SCHEDULED MAINTENANCE
Maintenance can be scheduled according to litres or number of coffees dispensed.

AUTO-ON, AUTO-OFF AND DAY-OFF FUNCTION
Programmable on-off timer for each day and/or daily timetables.

AUTOMATIC CLEANING CYCLE
Process for coffee groups cleaning.

ENERGY SAVING SYSTEM
Component insulation and smart electronics for maximum energy efficiency.

GROUP FLUSHING
With a simple pressure of the button a small quantity of water is dispensed to allow the group to be always clean.

- Optional**
- STAINLESS STEEL NAKED PORTAFILTERS** (INOX)
 - HIGH POWER STEAMER TERMINAL** (bigger holes diameter)
 - TALL VERSION**
 - EXTERNAL VOLUMETRIC PUMP**
 - ENHANCED RESISTANCE**

Standard models

wide range of models



✓ **Opera Steel**
Standard back panel: |BP1|

OPERA 2.0 THE REVOLUTION



✓ **Opera Black**
Standard back panel: |BP5|



Choose the panel

to suit your style

SANREMO

OPERA 2.0
THE REVOLUTION

BP1 Etched crystal /
backlight

SANREMO

OPERA 2.0
THE REVOLUTION

BP2 Painted wood

SANREMO

OPERA 2.0
THE REVOLUTION

BP5 Black /
backlight



Back panel of each version can be customized, with finishes that complement your style and needs.



✓ **Opera White**
Standard back panel: |BP2|



Everything in an App

app dedicated to parameter settings for tablet

(step A) GROUP SELECTION

(step B) PUSH / PULL LEVER SELECTIONS OF BUTTONS

(step C) SELECTIONS OF PROFILE BUTTONS PUSH / dose 1,2,3 PULL / dose 4,5,6

(step D) TEMPERATURE REGULATION

(step E) DOSE REGULATION

(step F) INFUSION REGULATION

The screenshot shows the app interface for a SANREMO coffee machine. It features a central image of the machine with buttons for 'Single', 'Double', 'Dose 1', 'Dose 2', and 'Dose 3'. Below this are three main sections: 'Temperature Regulation' with sliders for Steam (123.0 °C), Brew (93.0 °C), and Group (92.1 °C); 'Dose Regulation' with sliders for Ground coffee (7 g), Brew water (73 ml), and Coffee weight (0 g); and 'Infusion Regulation' with sliders for Pre Infusion (2.5 s, 3.5 bar), Main Infusion (71 ml, 9.0 bar), and Post Infusion (2 ml, 3.5 bar). A 'Brew Ratio: 0%' indicator is also present.

For each group it is possible to set:

Temperature

- water temperature T2
- group temperature T3
- steam temperature T5 (unique boiler for all groups)

Dose

- weight of ground coffee
- water dose
- pump pressure
- coffee weight

Infusion

- timing
- pump pressure
- amount of water

With the interface "Express yourself", the barista has total control of the extraction phase of his coffee and can manage each dispensing parameter according to his experience and professionalism.

To configure and set all the parameters of the machine, a specific App has been designed, which runs on tablet.

The application "Express yourself" utilizes a graphic interface, it is both user friendly and intuitive. This interface allows the user to set each groups relative parameters accurately for the perfect extraction.

Upon choosing the group (step A) and assigned a configured profile (step B,C) will define the general parameters of extraction: temperature and doses (step D,E). At the end it is possible to adjust the parameters relative of the 3 extraction's phases: pre-infusion, main infusion, post-infusion (step F).

Pre Infusion: 2.5 s
3.5 bar

Infusion: 71 ml
Pressure: 9.0 bar

Post Infusion: 2 ml
3.5 bar

(step F) Adjust the 3 extractions phases

This operation is simplified by the App. Everytime the user modify one of these parameter the software update automatically. What was set prior to the modification.

PRE-INFUSION



INFUSION



POST-INFUSION



CONFIGURATIONS

- STANDARD
- STRONG
- BALANCED
- SWEET & LIGHT
- ... N (set by the user)
- ... N (set by the user)

It is possible to save and recall new configurations set by the user or the default ones, specifically designed to allow even the less experienced bartenders to obtain immediately excellent results in the cup.

Clicking in "save new configuration" you can save your perfect espresso dispensing menu and transfer it into another machine.

Opera wi-fi

simplify things



14 From today the Opera 2.0 is easier to handle, thanks to the **Sanremo Cloud** and **Webapp Expressyourself** interface, for an even easier and interactive using experience.

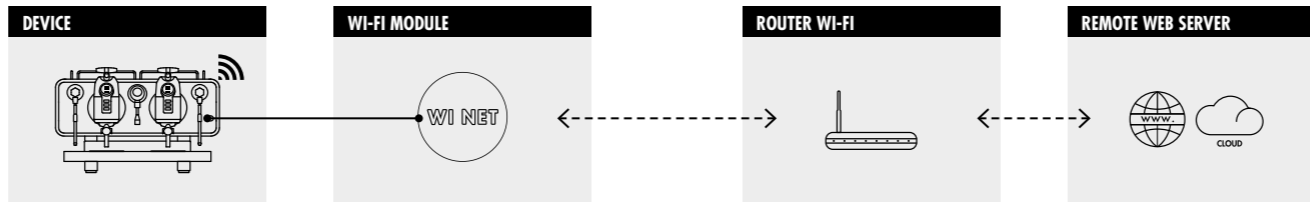

- Handling through Sanremo app, from smartphone, tablet, or pc, of all configuration parameters of the machine, without the need for physically being in front of it.
- Possibility of connecting multiple machines simultaneously for sharing, modifying, and setting of recipes and configurations.
- Simultaneous monitoring and handling of multiple machines by the same owner (e.g.: franchising in different locations).
- Statistical analysis of consumption, distribution, maintenance, configuration for all connected machines.
- Remote maintenance by the technician for updating, verification of the correct settings and parameters control.

INTRANET (WI-FI LOCAL NET)

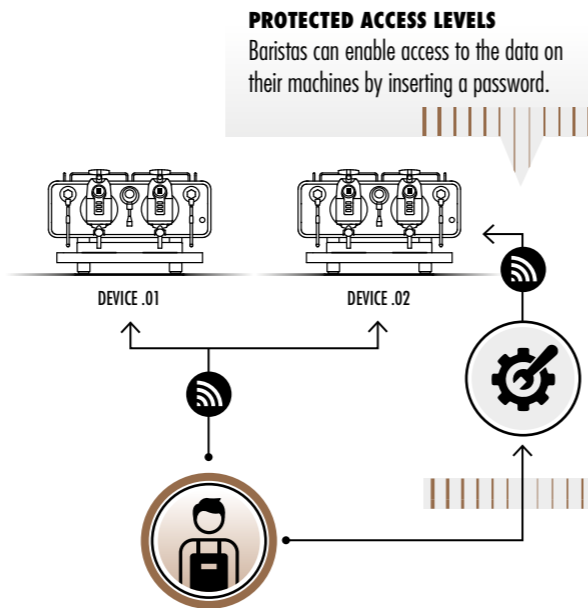

PROTECTED ACCESS LEVELS
Baristas can enable access to the data on their machines by inserting a password.

- PLUS + (USING THE LOCAL WI-FI NETWORK)**
- Reading and changing machine settings and parameters
 - Consumptions analysis for a better stock management
 - Meters reading of the coffee dispensed
 - Saving, restoring and sharing of settings (recipes) on your machines

Data exchange can only be effective in the wi-fi range.

INTERNET (GLOBAL NET) / SANREMO CLOUD

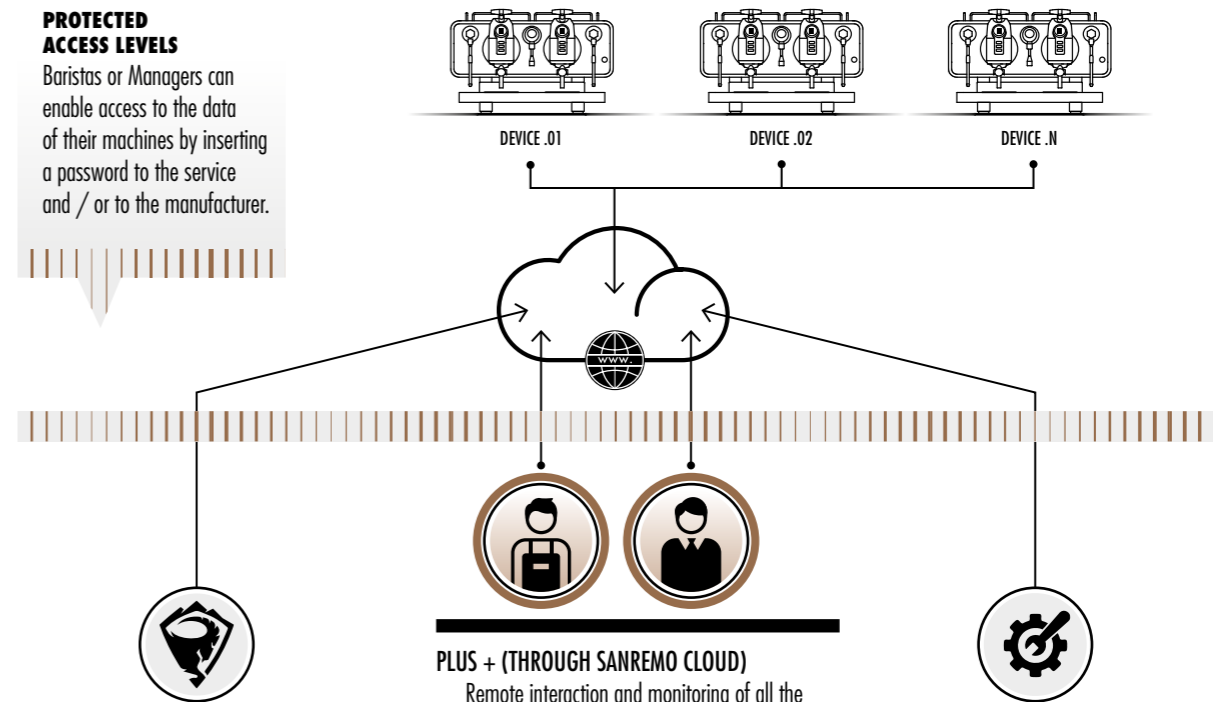

PROTECTED ACCESS LEVELS
Baristas or Managers can enable access to the data of their machines by inserting a password to the service and / or to the manufacturer.

- PLUS + (ENABLING THE MANUFACTURER)**
- Sending of App updates to the machines
 - Sending new settings (recipes)
 - Clearer and faster data collection aimed to resolve any technical/constructive problems
 - Useful information for the improvement and evolution of the product
 - Direct and continuous contact with the manufacturer

- PLUS + (THROUGH SANREMO CLOUD)**
- Remote interaction and monitoring of all the functions and performances of the machine
 - Reading and changing of the machine settings
 - Display of historical usage data
 - Consumptions analysis for a better stock management
 - Meters reading of the coffee dispensed
 - Saving, restoring and sharing of settings (recipes) on your machines

- PLUS + (ENABLING THE SERVICE)**
- Immediate report of anomalies
 - Diagnosis and possible remote troubleshooting
 - Reduction of machine downtime
 - Logistic planning and organization of maintenance interventions

- BARISTA**
- MANAGER**
- MAINTENANCE SERVICE**
- MANUFACTURER**
- SANREMO CLOUD**
- INTERNET GLOBAL NETWORK**
- LOCAL WI-FI NETWORK**